

DRI UPDATE

SIMA

Sponge Iron Manufacturers
Association

Indian voice for the ore based
metallic & steel industry

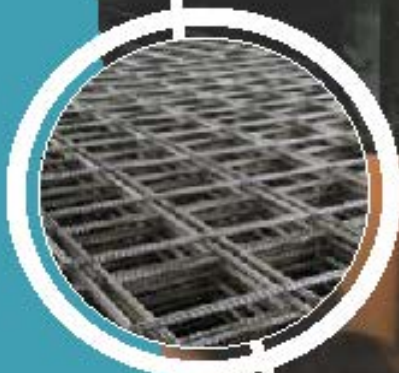

September, 2018



EDITORIAL



Dear Readers,

After a long time smile has come back on the faces of DRI & steel producers. Undoubtedly, it is due to the many policy initiatives taken by Government of India and particularly Ministry of Steel. Presently, there is a good demand of steel from infrastructure, housing and automobile sectors leading consumption growth out pacing production.

Major impediments in the steel growth are restricted availability & high price of iron ore/pellets and non coking coal. SIMA has been flagging these issues at different forums. We believe that Government will take some steps to resolve them .

It has been endeavor of SIMA to disseminate the knowledge about the latest innovations for the sustainable growth of Indian DRI and steel industry. With this in view, SIMA organized 4th India International DRI Summit, 2018 on 13th August, 2018. The event was attended by Union Minister of Steel, Member, NITI Aayog, Union Secretary of Ministry of Steel. Experts from USA, UK, Austria, China, UAE and India presented the papers. Besides them, more than 175 stakeholders attended this prestigious event. Glimpses of the summit have been included in this edition.

It is a matter of proud for us that some of our members have got the national awards from the Hon'ble Steel Minister details of which have also been included in this edition.

I wish a very bright future to our readers.

Deependra Kashiva
Executive Director

CHAIRMAN'S MESSAGE



The issue of "DRI update" brings to you yet another initiative of SIMA. You may recall our jointly hosting an investors conference in Mumbai on August 13 last year, or the participation of SIMA in the task force set up by NITI Aayog during November to or the contribution to drafting of the NSP, organizing international conference, meeting sponge iron makers who are non members of SIMA to make them aware of SIMA activities, getting KPMG to study the sponge iron industry prospects and so on. There are some more initiatives in the pipeline. DRI Update is intended to communicate to you a larger picture of sponge industry. We hope that you stand to get such updates periodically and also get an opportunity to contribute by your views, your questions or comments through this update.

I wish SIMA and DRI Update a great success.

D.P. Deshpande

Vice CHAIRMAN'S MESSAGE



SIMA has been in the forefront of Policy advocacy for the qualitative enhancement of the Indian Steel sector especially with regard to the need to ensure adequacy and accessibility of raw material and also in joining hands with other stakeholders to provide an environment of growth for this core sector. It is indeed heartening that SIMA has been the torchbearer for enabling the growth of the Sponge Iron industry in India. The initiation of an independent study of this sector for the developmental and growth of the sponge iron industry and the implementation of the key suggestions made therein should further galvanise the industry. The international DRI summit and the deliberations therein reinforces the role SIMA has continued to play over the years towards ensuring quality inputs for the steel sector.

Shivramkrishnan H.

Innovations – Key to Survival and Sustainable Growth of Indian DRI industry

Deependra Kashiva, Executive Director
&
D.P. Deshpande, Chairman
Sponge Iron Manufacturers Association

Indian DRI industry's growth journey started with the initiative of Ministry of Steel when they set up a demonstration plant at Paloncha in 1980 with the assistance of UNDP to test the suitability of Indian iron ore and non-coking coal for the production of DRI. The basic reason for this move was second highest foreign exchange outgo in the form of import of steel melting scrap which is alternate to the DRI.

Then in 1983, Odisha Sponge Iron Limited set up India's second coal based DRI plant. The third coal based DRI plant was set up by Tatas in 1985 based on their own technology. To push up further growth, DRI industry was de-licensed in 1985 baring certain location restrictions much before the de-licensing and deregulation of Indian economy in 1991.



DRI capacity was doubled during 2005-10 basically to meet the surge in steel demand as DRI based steel plant can be set up in 2 / 3 years period compared to the 8/10 years normally taken by Blast Furnace based steel plants. To put a further push to the DRI, production and easily availability of natural gas, three coast based DRI plants came into existence between 1990 and 1993. Today with a capacity of 46 Million Tonnes per annum and production of more than 24 Million Tonnes, India is largest DRI producer in the world. Indian DRI industry within it's existence of 23 years became world's largest producer is maintaining this distinguish achievement since last 15 years.

But during this journey, the industry faced many problems some of which are still continuing such as restricted availability of iron ore and its high price, uncertainty in the availability of non coking coal, non availability of natural gas, high level import of steel melting scrap, logistic

related issues, lack of technology drive, etc. These issues are not being covered in this article as the focus of the article is on innovations.

Coming back to the theme of this paper following will demonstrate how innovations can lead higher productivity without much capex and will in turn ensure better financial performance:

There are over 300 DRI plants in India. Out of which at least 100 rotary kilns are of the size 350 TPD and above. Many of them have already started to produce at 400 TPD. Arguably these

kilns can be expected to produce upto 500 TPD at lower specific coal consumption to meet/exceed BEE requirements. This can be achieved by reducing waste gas volume, proper mixing of raw materials, increasing the rates of reduction reactions, and importantly performing outside certain amount of activities that the kiln currently does. It is about use of



understanding of rotary kiln operation and deploying technological developments in its operations. One side effect of this approach is lower specific power generation. In fact, specific power generation can be a good measure of the success of this approach.

The following paragraphs will illustrate on each of the above mentioned factors:

1. Getting to limits of the fill factor and throughput

The first question to ask is whether we are sure that the kiln is fully being used or not. If we benchmark with the airlines, one of their practices is to overbook to nullify the effect of last minute cancellation and converting such revenues into the incremental profits of the airline. Can the rotary kiln operations take this approach? When and how do we know that there is a room to improve the filling factor? All of these questions are to be answered in a frame where quality of DRI is not compromised.

The kiln processes are set and kept running at a particular level to ensure that the average quality of DRI produced meets the minimum quality requirements. This is so done no matter what the temperature inside is or what quality of iron ore allows as an opportunity. The RPM is set also to deliver quality on an average. RPM is an important tool in the hands of the operator. RPM also influences to what extent throughput can be increased.

The other factors for influencing throughput of the kiln are the closeness of particle size of the feedstock of iron ore and non-coking coal. It explains why kilns using pellets give higher throughput compared to kilns using iron ore. Reduced fines and uniform size together create a condition that allows kilns to be filled more and faster. Arguably, iron ore feeds can achieve equally high throughput, if the iron ore is good in strength and more uniform in size.



Pellets typically used in DRI plants

Presence of fines and mixed sizing causes reduction in the active layer volume. This layer is responsible for heat and mass transfer in the solid bed. Accordingly, multiple kilns of the same size shall have multiple volumes of active zone and therefore shall have different production levels. The trick to higher throughput lies in enlarging the active layer volume. The larger the volume, the faster is the heat transfer. In other words, less is the temperature differential between the free space and the solid bed. For the same refractory lining, one raises the solid bed temperatures and rates of direct reduction which lead to higher production.

Another factor that influences the active layer volume is the right RPM. Higher or the active layer volume reduces if the rolling of particles does not happen in the kiln. And rolling of particles depends on RPM and the angle of repose of the particles/mix of the particles. Presence of fines changes the angle of repose and the pattern of rolling. Instances of sudden change in pattern of metallization of lumpy particles and fines, is explained by this internal phenomenon.

If the kiln is filled up by irrelevant particles, the effective volume for the relevant particles drops as much and it will impair the effort to produce more. Irrelevant materials are ash in coal, or clay or such fines coming with iron ore, impurities in a low grade dolomite etc.

In fact, one can stretch the thinking and say that coal that only provides heat and does not participate in solid-solid reactions also should stay away. So reduction of C/Fe also is like creating more operating kiln volume. The above can be summarized that one should fill the kiln more/fast with C & Fe and have a large active layer volume to get higher throughput without sacrificing the quality of the DRI.

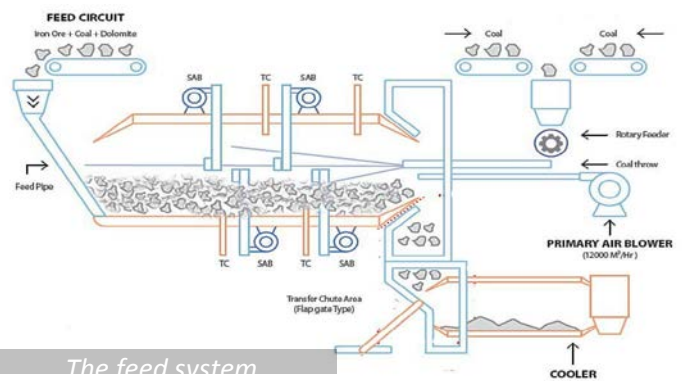

2. Reduction in waste gas volume

The waste gas volume passing through the free space in the kiln creates a certain velocity. Higher the volume, higher is the velocity for the same composition of waste gas and given filling factor. As the filling factor improves, the free space shrinks and waste gas velocity goes up. The velocity helps in heat and mass transfer rates. So there is a need for a minimum velocity. However, if the gas velocity goes very high as it will with higher filling factor, the CO surrounding the iron ore particle is swept away faster. Higher velocity will cause a tendency of back mixing, effectively reducing useful volume of the kiln. There is an optimum point.

One of the ways to move the velocity point in the favorable direction is to reduce the gas volume by proper design. Reducing excess air is one way and introducing oxygen in place of air is another way.

3. Rates of reduction reactions

Higher the temperature, higher are the reaction rates for carbon consumption to generate heat and also for carbon monoxide to react with iron ore. Higher the reaction rates, the lower is the requirement of residence time and higher is the possibility of increasing throughput. A 25 degree change in temperature, using suitable refractory, without increasing the thickness of the refractory can enhance the reaction rates by 6%.

One way to maintain average temperatures high without taking the peak temperature up, is to reduce instances of drop in temperature or change the shape of temperature to length curve, and thus increase the average temperature. The main causes for a drop in average temperature are low temperature inputs like coal, iron ore, and even air. Preheating and drying of input materials, primary air etc. would lift the average temperatures.



4. Mixing of contents

This is about setting proper RPM of the kiln. Without rotations of the kiln, there would be no mixing. With low RPM, there will be slipping. With high RPM, there would be kind of centrifuging. Right RPM would lead to big active layer of rolling particles in the kiln, getting heated and resulting faster reduction reaction.

Mixing also gets decided by the presence of fines in the material mix. Fines have a different angle of repose than the solids and will interfere in the formation of active zone. Fines can lead to a formation of "kidney" which can be detected by unreduced fines.

New developments of rotary kilns use lifters to cause proper mixing and heat transfer. The reported data suggests over 40% improvements in all parameters, such as production rate, specific heat consumption etc.

5. Getting some of the " kiln work " done outside the kiln

This is the best chance to take a quantum jump in production level. Some of the plants have been operating with a preheating kiln, bringing iron ore at over 800 deg Celsius. For a 100 TPD kiln, this alone has taken the production to 150 TPD. A 350 TPD kiln can simply go to 500 TPD production level by just one action.

Next course of action is preheating primary air and coal injection. In fact, wherever coal injection is used, it is always preheated. Both the air and coal are usually preheated by waste gas, or by external indirect heating. Even if the preheating process takes external heat and extra energy in terms of the pressure drop; the additional cost would not only pay for itself but would also return well by sheer release of kiln space and raising kiln productivity.

6. More on gas injection in the kiln

Even a better option could be to gasify the injection coal, partially and inject heated coal gas inside the kiln. One would release even more space inside the kiln for direct reduction. The gas will burn inside the kiln in competition to the coal and provide the required heat/temperature.

In a typical coal injection act, nearly 50 percent of the coal is injected. The injected coal needs to be 3 to 6 mm in size. More often in Indian kilns, the entire minus 6 mm coal is injected.

This coal has about 40% fines of the size minus 3 mm. The zero fines would readily burn away like gas would. The rest coal will drop on the active layer and cause disturbances. A lot of this coal comes out as unburnt in the form of char and ash. If we examine the coal injection and the role it performs in the DRI production, it looks possible that all these roles can be better played by gas. The following are the advantage of gas injection:



1. The zero fines are substituted by gas, the ash carryover will get reduced.
2. The undersize fraction that is supposed to supplement carbon, could serve the role but would disturb the active layer process. The gas as its substitute, with injection burners directed towards the bed would do what coal would have done without any disturbance.
3. The flame length can be adjusted more easily, if gas is injected.

When gas is injected, coal could be made to participate more in carbon solution reaction as compared to the case where there is no gas injection. The gas injection burners could also be directed towards rolling active layer for better heat transfer.

Now the question arises as to what should be the calorific value of the gas? The higher calorific value of the gas is a better option to avoid ingress of avoidable inerts that would reduce the partial pressure of the reactant gases. It should have more carbon than hydrogen, or a sufficiently high C/H ratio.

7. Effect on coal consumption on power production

With many of the above actions, the overall coal consumption (or C/Fe ratio) may drop due to energy efficient marginal production. The C/Fe could be broken up as C/Fe in the kiln and C/Fe outside the kiln. There would be more drop in C/Fe kiln, for actually performing some coal consumption outside the kiln.

Since the whole exercise is about reducing specific fuel consumption, there would be associated reduction in specific waste heat generation, but with associated increase in DRI production, there would be no reduction in power production.

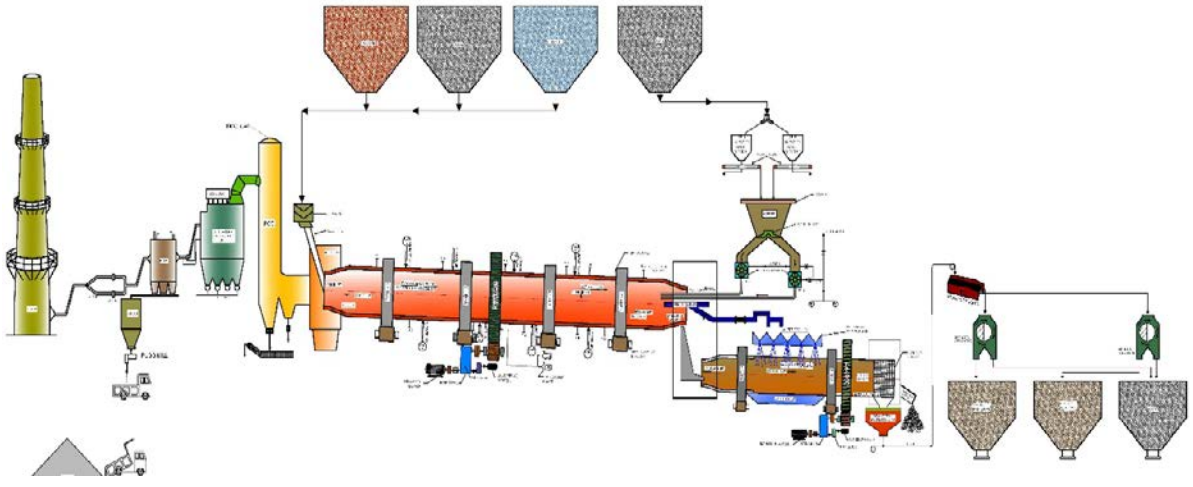

DRI manufacturing & Power generation flow diagram

To summarize, the efficient way of production of DRI with reduction in the carbon foot prints and increase in productivity is desirable from the national perspectives to augment the steel production in the country to meet it's fast growing demand.

Fuelling Iron making, Present and Future

Todd M. Astoria, P.E.

Midrex Technologies, Inc.
3735 Glenn Lake Drive, Suite 400, NC, USA 28208
Phone: +1 704-423-3369
Email: tastoria@midrex.com

INTRODUCTION

Natural Gas has fuelled the growth of DRI plants and will continue to be an important driver for Direct Reduction Ironmaking growth in the future; however, many iron and steel producing regions are facing limitations on the availability of natural gas, and/or increasing natural gas prices. On the conventional BF-BOF route there is increasing pressure on the supply of coking coal of sufficient quality that is required by the modern-day blast furnace. This paper will review some of the current trends and options for fuelling the Midrex® Process with special emphasis on the Indian market scenario.

A BRIEF COMPARISON OF THE CURRENT ART

Figure 1 lists the worldwide crude steel production by process route:

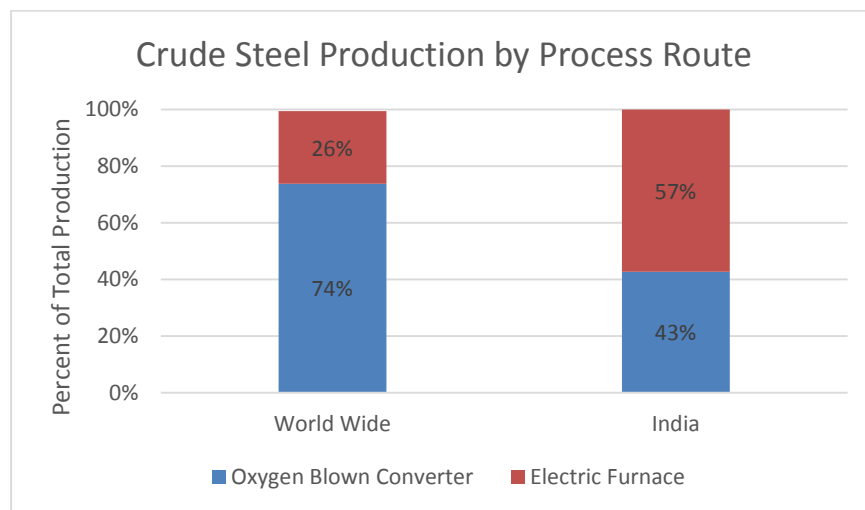

Figure 1: Crude Steel Production by Process Route¹

Figure 1 shows that the Oxygen Blown Converter (OBC) and Electric Furnace (EF) account for over 99% of the total worldwide steel production. The charge material for the two routes varies by region; however, generally the OBC feed mix is heavily dominated by Hot Metal from the blast furnace (BF), and the EF feed mix is heavily dominated by scrap with a significant fraction composed of alternate iron units such as Direct Reduced Iron (DRI).

¹ Source: World Steel Association, Steel Statistical Yearbook 2017

Figure 2 shows additional analysis related to the EF route:

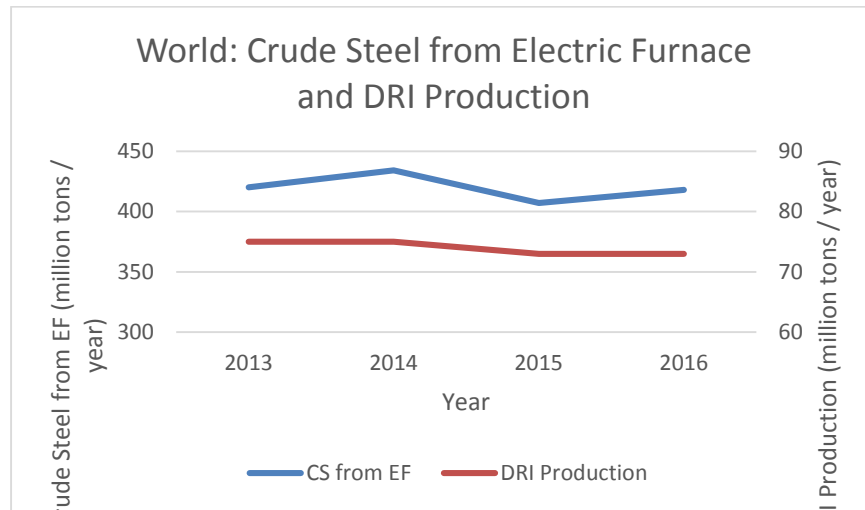

Figure 2: World EF Crude Steel and DRI Production Comparison^{2,3}

Figure 2 shows that the total crude steel produced by the electric furnace route is in the range of 400 to 420 million tons over the last several years. Correspondingly, this implies that DRI comprises approximately 15% to 18% of the worldwide EF charge mix⁴.

Figure 3 shows the specifics for the Indian scenario:

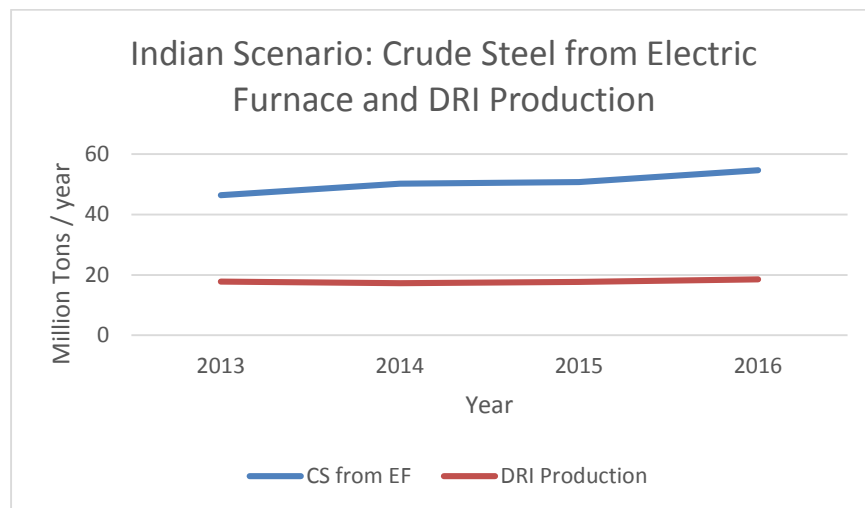

Figure 3: Indian Scenario: CS from EF and DRI Production^{5,6}

Figure 3 indicates that for the Indian scenario, DRI comprises over 25%⁷ of the charge in electric furnaces. Figure 2 already shows that the worldwide average is 15% to 18% which is significantly lower than the percentage from the Indian scenario.

² Source for CS Production: World Steel Association, Steel Statistical Yearbook 2017

³ Source for DRI Production: Midrex World Direct Reduction Statistics 2017

⁴ Considering 2016 production numbers with 85% conversion of DRI to CS and 90% conversion of scrap to CS

⁵ Source for CS Production: World Steel Association, Steel Statistical Yearbook 2017

⁶ Source for DRI Production: Midrex World Direct Reduction Statistics 2017

The Indian scenario also has a distinct difference in the DRI process route compared to the world trend, and it can be seen in Figure 4:

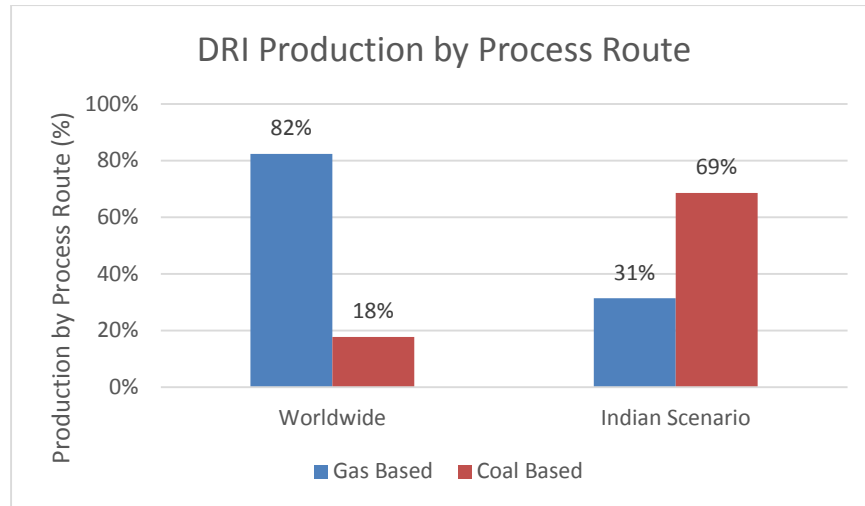

Figure 4: DRI Production by Process Route⁷

Figure 4 shows that the Indian scenario DRI production is heavily dominated by the coal based route. In 2017 India produced approximately 22 million tons of DRI, and about 7 million of those tons were produced by gas based DRI technology. The Indian coal based DRI production accounts for virtually all the worldwide coal based DRI production.

The current state of the market can be summarized that the BF/BOF combination continues to be the dominant steelmaking process route followed by the electric furnace technologies. Worldwide DRI is a small but growing portion of the metallics balance and is mostly using gas-based technologies.

The Indian scenario contrasts with the world trend in that the EF route is adopted at a higher rate and coal-based DRI production is favoured over gas-based DRI. The availability of fuel is one of the key considerations driving the Indian market and factors heavily into the following discussion.

FUEL FOR THE MIDREX® PROCESS

This paper will not go into the details of ironmaking fundamentals since it is assumed that the audience already has expertise in the field of ironmaking and steelmaking. For the convenience of this discussion, it will be assumed that when discussing the various process routes the predominate fuels are identified in Table 1:

Table 1: Predominant Fuels of for Iron and Steelmaking

Ironmaking Route	Fuel Options
Blast Furnace	Coking Coal (dominant) Non-coking coal
Gas-based Direct Reduced Iron	Natural Gas Coal (gasification-based technologies)
Coal-based Direct Reduced Iron	Coal

⁷ Source: Source for DRI Production: Midrex World Direct Reduction Statistics 2017 for the 2017 year

Table 1 clearly indicates why the Indian scenario is different from the worldwide trend. Since 2007, India has increased the crude steel production from approximately 53 million tons up to approximately 95 million tons in 2016⁸. The major steel companies have installed and upgraded significant new capacity for the blast furnace route. However, the fraction of crude steel produced by the electric furnace route in India has not significantly diminished even with the large added blast furnace capacity, as can be seen in Figure 5:

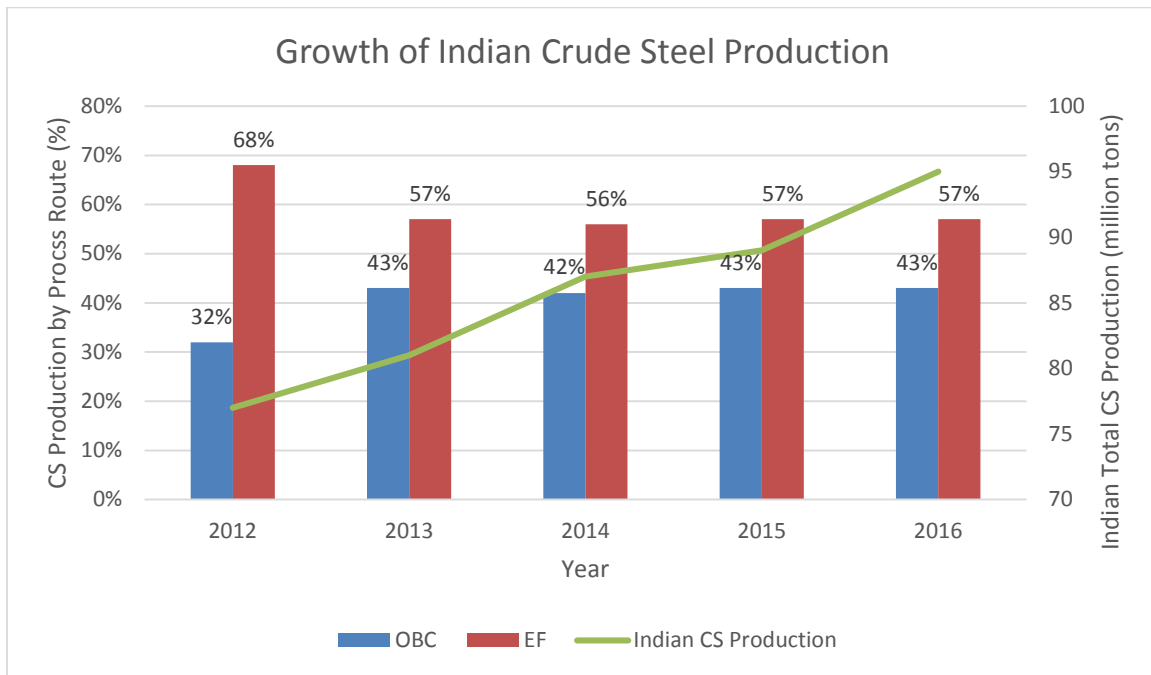

Figure 5: Growth of Indian Crude Steel Production⁹

These statics lead to the conclusion that the availability and price of fuel in the Indian scenario will drive production and technology decisions for iron and steelmaking. Most importantly, coking coal and natural gas currently have less availability. **Therefore, for the Indian scenario it is mandatory to maximize the use of non-coking coal or another plentiful fuel resource.**

Figure 6 shows the fuel flexibility for the Midrex® Process:

⁸ Source: World Steel Association, Steel Statistical Yearbook 2017

⁹ Source: World Steel Association, Steel Statistical Yearbook 2017

MIDREX® DIRECT REDUCTION PROCESS FLEXIBILITY

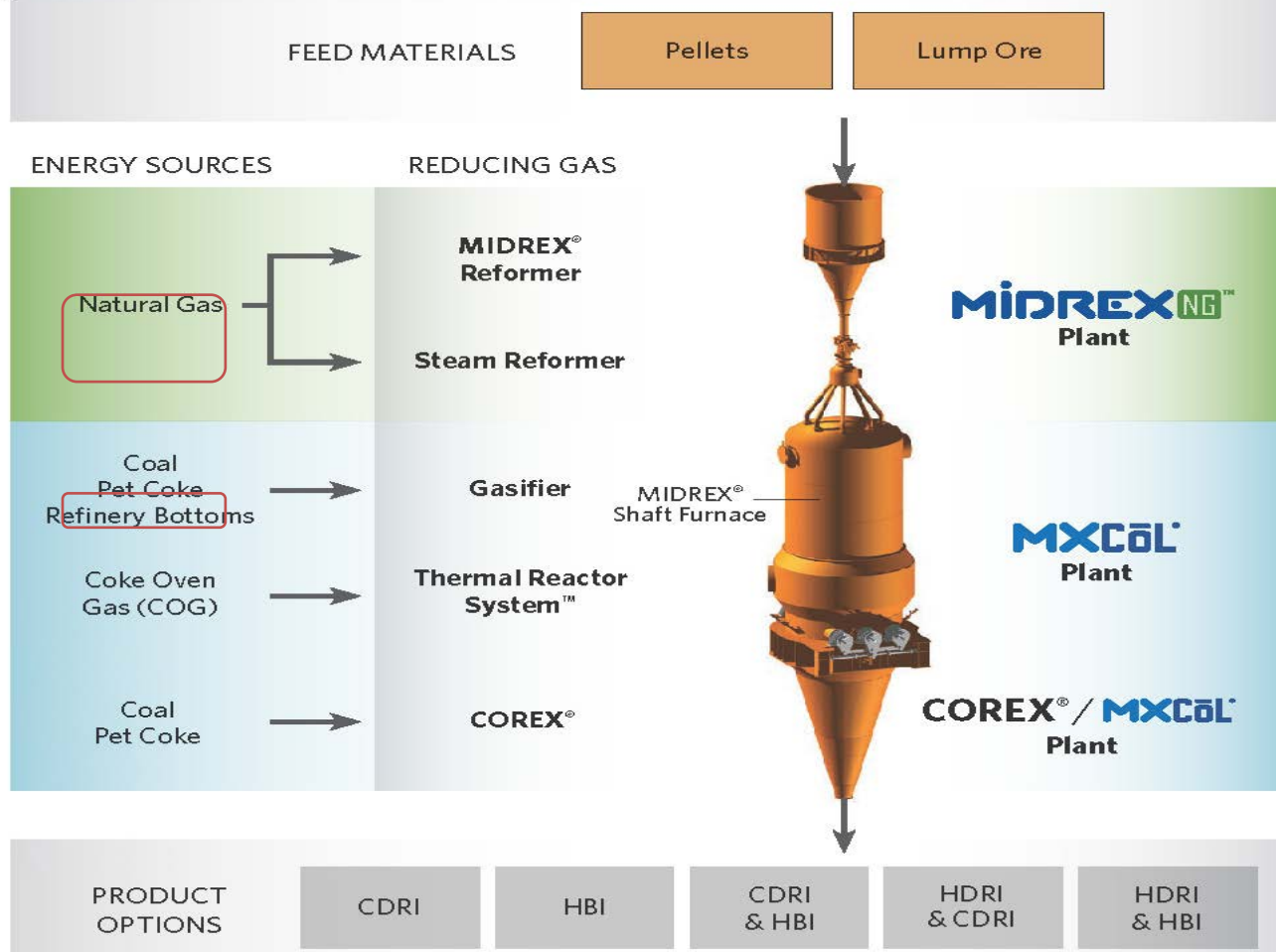

Figure 6: Midrex(R) Process Fuel Flexibility

The two fuels of interest from Figure 6 are natural gas and coal. The previous section has noted that natural gas itself has the supply limitation for iron production; however, the critical and desired component of natural gas that is required by the Midrex® Process is methane.

One important development on the international market is the return of gas-based production of DRI to the USA. From 1970 to 1997 the USA had a combined total DRI production of about 10 million tons of DRI¹⁰. Then from 2001 until 2013, there was negligible or no DRI production. However, after the introduction of hydraulic fracturing technology to produce natural gas the market condition was changed. As of 2017, there are multiple DRI plants in operation in the USA producing roughly 3 million tons of DRI. There is also an additional natural gas-based DRI facility is under construction in the USA and expected to start up as soon as 2020.

The USA condition is an important analogy to the Indian scenario due to Coal Bed Methane (CBM). The estimated Indian CBM resources are around 2,600 billion cubic meters (92 trillion cubic feet)¹¹. In 2016, the USA had an estimated shale gas resource of 210 trillion cubic feet¹².

¹⁰ Source Midrex World Direct Reduction Statistics 2017

¹¹ Source Government of India, Ministry of Petroleum and Natural Gas 2017-2018 Annual Report

¹² Source Department of Energy, US Energy Information Administration

The Orissa and West Bengal area have estimated CBM reserves of 460 billion cubic meters¹³. CBM is a direct substitution of natural gas in the Midrex® process, and if these resources are developed, then gas-based DRI may become a viable option in the future.

However, for India the current abundant resource is non-coking coal. The Indian reserve of non-coking coal is 279 billion tons¹⁴. Midrex has continued to work with our partners to further develop and define the MXOCL® Plant. The MXCOL® Plant is designed specifically for Grade E and Grade F coal for high efficiency and cost-effective production of DRI.

Direct Reduced Iron Future Fuels

There are some additional fuel developments that should also be mentioned. In the short and midterm, coal and natural gas will continue to be the driving factors. However, some international market segments are starting to see additional pressures that are driving research into alternate fuels.

In Europe, the OBC route is still favoured over the EF route. Approximately 60% of the crude steel produced in the European Union (EU) in 2016 was produced through the OBC route. However, the EU steelmaking industry is starting to face environmental and financial pressure to drastically reduce their CO₂ emissions. Since the BF / BOF route produces much more CO₂ than the DRI / EF route there is starting to be additional study and interest in evaluating the DRI / EF route.

However, according to the EU targets, simply adopting the DRI / EF route reduce the CO₂ emission sufficiently by their own, so there is increasing interest in even lower CO₂ emission ironmaking technologies.

One advanced ironmaking technology option is Midrex® H₂. The flowsheet is shown in Figure 7.

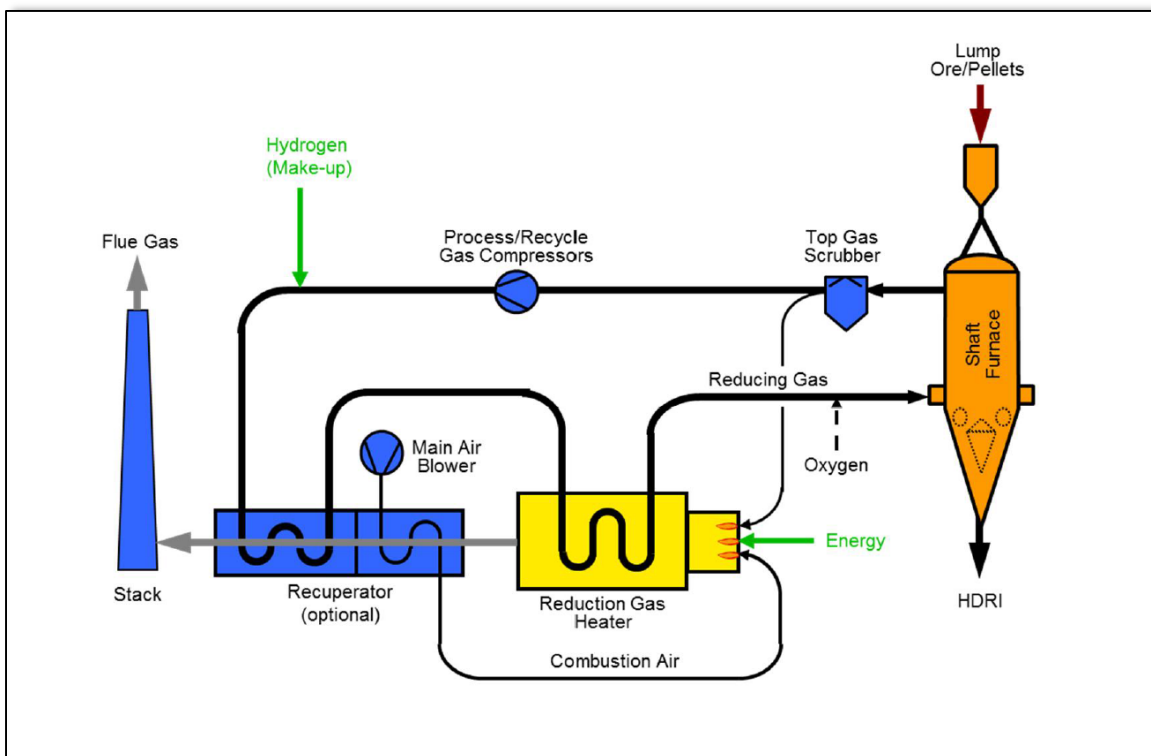

Figure 7: Midrex(R) H₂ Flowsheet

¹³ Source Government of India, Ministry of Petroleum and Natural Gas 2017-2018 Annual Report

¹⁴ Source Government of India, Ministry of Coal 2017-2018 Annual Report

If the hydrogen is produced from a 'green' source, then the CO2 emission from the DR Plant can be drastically reduced. In commercial operation, the Midrex® Process is already operating with H2 concentrations of at least 55% and up to approximately 70%. Because hydrogen is already used in large amounts in the Midrex® Plant the technology risk is greatly reduced if industrial quantities of green energy can be produced.

Global Scrap and DRI Outlook

Shruti Salwan

Metals Analyst, Metal Bulletin Research

4th India International DRI Summit 2018

13 August 2018, Delhi

Disclaimer:

- *Prices and other information contained in this presentation have been obtained by us from various sources believed to be reliable. This information has not been independently verified by us. Those prices and price indices that are evaluated or calculated by us represent an approximate evaluation of current levels based upon dealings (if any) that may have been disclosed prior to publication to us. Such prices are collated through regular contact with producers, traders, dealers, brokers and purchasers although not all market segments may be contacted prior to the evaluation, calculation, or publication of any specific price or index. Actual transaction prices will reflect quantities, grades and qualities, credit terms, and many other parameters. The prices are in no sense comparable to the quoted prices of commodities in which a formal futures market exists.*
- *Evaluations or calculations of prices and price indices by us are based upon certain market assumptions and evaluation methodologies, and may not conform to prices or information available from third parties. There may be errors or defects in such assumptions or methodologies that cause resultant evaluations to be inappropriate for use. Your use or reliance on any prices or other information published by us is at your sole risk. Neither we nor any of our providers of information make any representations or warranties, express or implied as to the accuracy, completeness or reliability of any advice, opinion, statement or other information forming any part of the published information or its fitness or suitability for a particular purpose or use. Neither we, nor any of our officers, employees or representatives shall be liable to any person for any losses or damages incurred, suffered or arising as a result of use or reliance on the prices or other information contained in this publication, howsoever arising, including but not limited to any direct, indirect, consequential, punitive, incidental, special or similar damage, losses or expenses.*
- *We are not an investment advisor, a financial advisor or a securities broker. The information published has been prepared solely for informational and educational purposes and is not intended for trading purposes or to address your particular requirements. The information provided is not an offer to buy or sell or a solicitation of an offer to buy or sell any security, commodity, financial product, instrument or other investment or to participate in any particular trading strategy. Such information is intended to be available for your general information and is not intended to be relied upon by users in making (or refraining from making) any specific investment or other decisions. Your investment actions should be solely based upon your own decisions and research and appropriate independent advice should be obtained from a suitably qualified independent advisor before making any such decision.*

Global Scrap & DRI Outlook

Demand for scrap has been growing

- Rising crude steel output with an emphasis on EAF
- Environmental aspirations in key consuming markets

**Metal Bulletin
Research**

Global steel production will continue to grow at a steady pace with MBR forecast suggesting growth at a CAGR of 2.1% by 2030

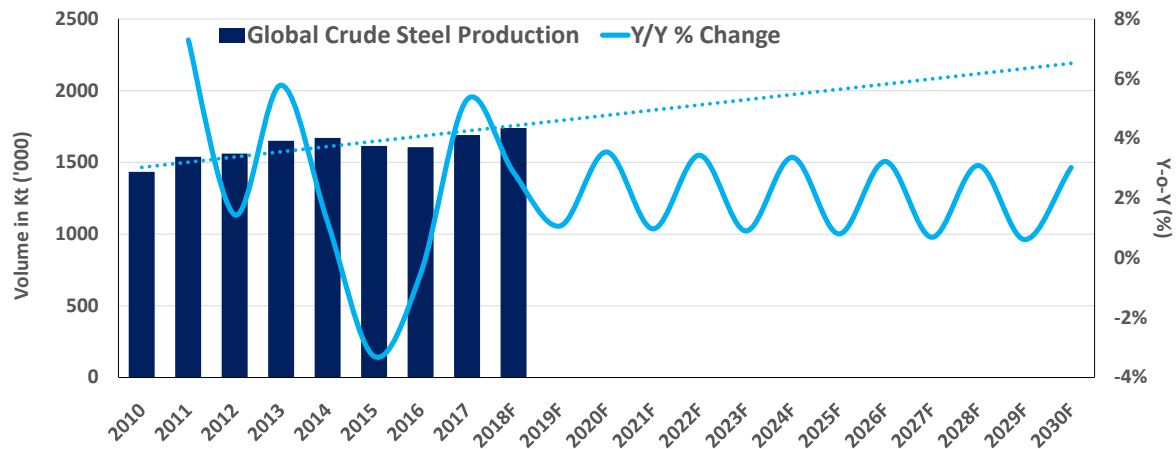

Source: WSA, Metal Bulletin Research

**Metal Bulletin
Research**

EAF steel production route is gaining prominence but the game-changing evolution from BOF to EAF in China is yet to happen...

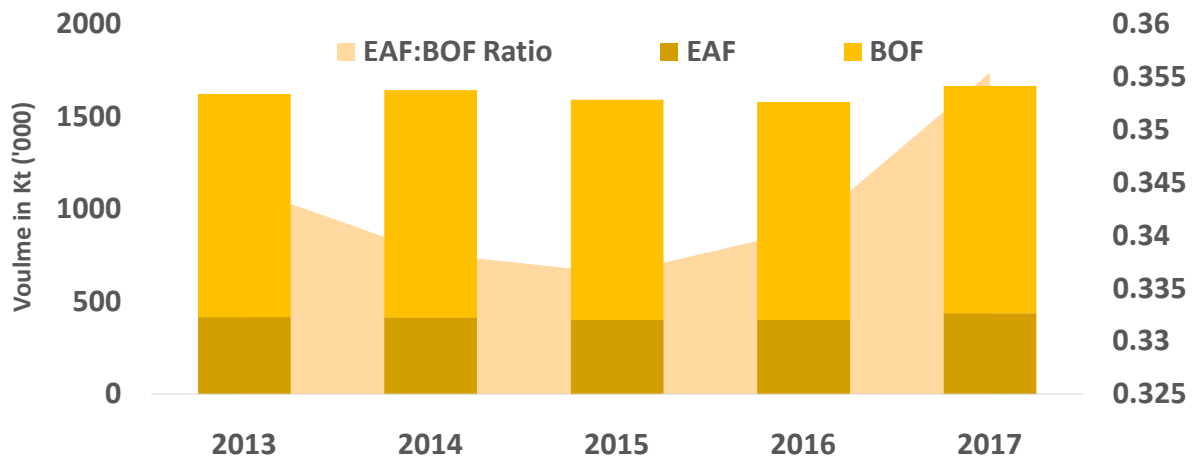

Source: WSA, Metal Bulletin Research



Demand from key ferrous scrap consuming markets is accelerating...

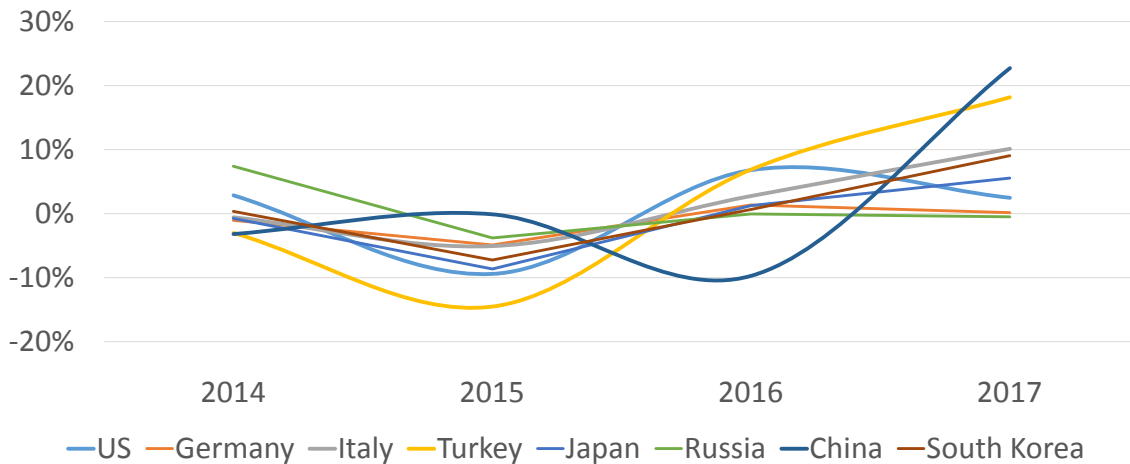

Source: Metal Bulletin Research



Global Scrap & DRI Outlook

Scrap remains comparatively low priced

- Scrap underperformed compared to other raw materials
 - Margins at steel mills hit record highs
 - Melting scrap is more appealing than re-rolling

Metal Bulletin
Research

Last year, domestic scrap prices in China remained relatively low against hot metal costs which prompted demand for scrap – whether the trend will continue is a big question?

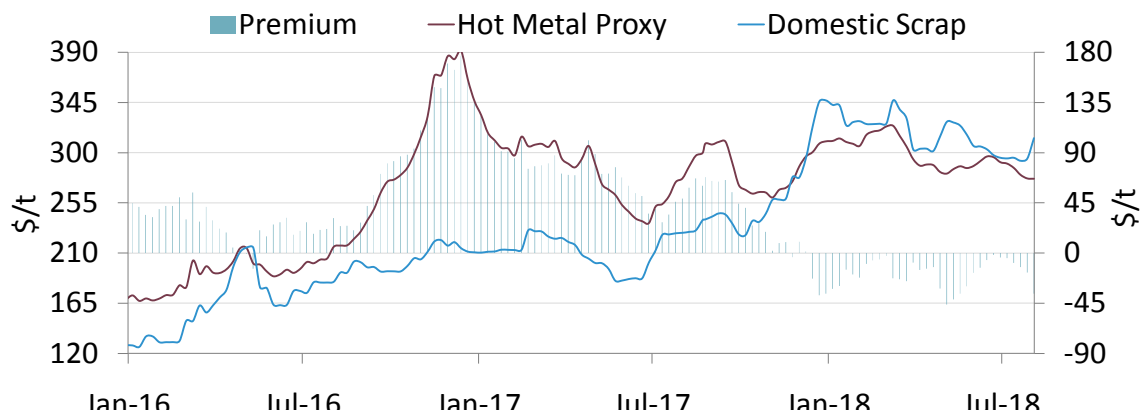

Source: Metal Bulletin, Metal Bulletin Research

Metal Bulletin
Research

HRC-scrap spreads widened after a massive push in US steel prices to unsustainable levels; European domestic demand remains sluggish compared to last year; Turkish spreads remain above the long-term average of \$200/tonne

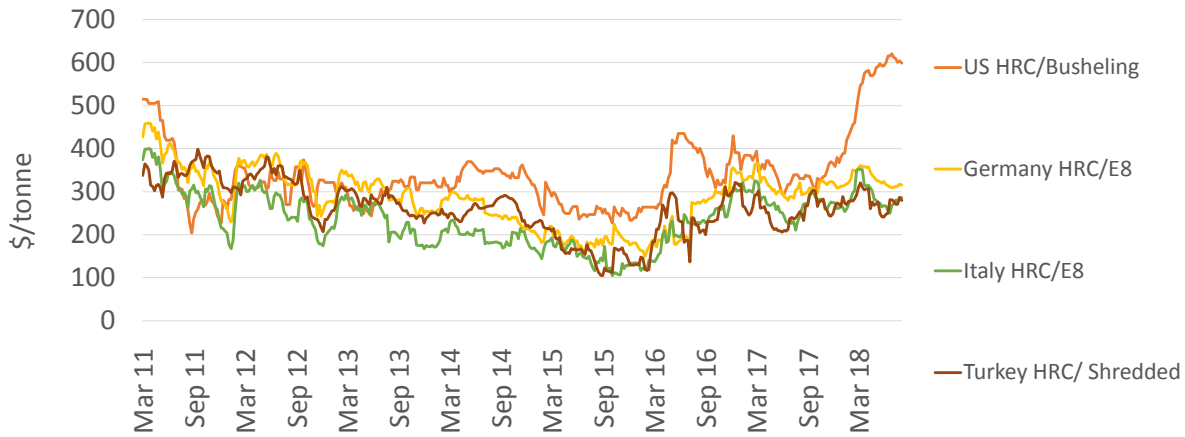

Source: Metal Bulletin, AMM, Metal Bulletin Research

Metal Bulletin
Research

Rebar-scrap spreads to break the record of previous highs as global trade protectionism pushes domestic regional prices in the US & EU up; growth in China's construction sector remains positive; while duties/currency deflation pushes Turkish prices

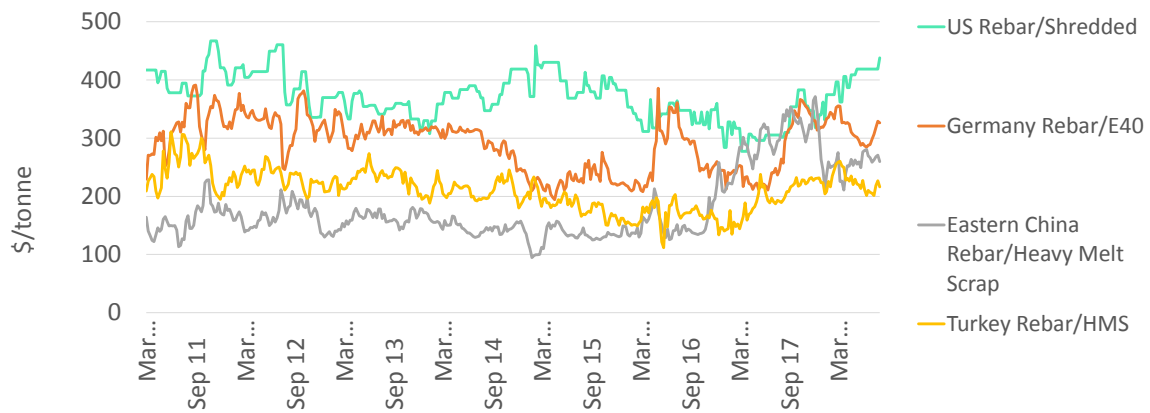

Source: Metal Bulletin, AMM, Metal Bulletin Research

Metal Bulletin
Research

Turkish market is a good illustration of slower growth in scrap prices making them more attractive against semi-finished steel products

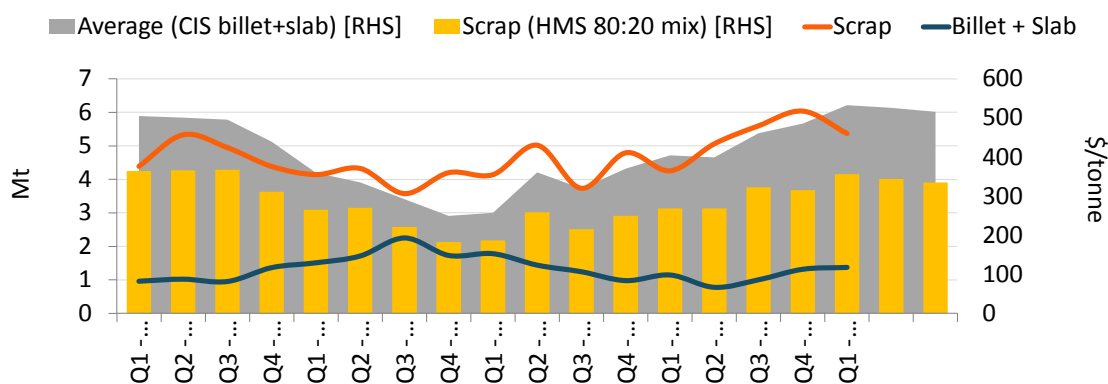

Source: TUiK, Metal Bulletin Research

MetalBulletin
Research

Global Scrap & DRI Outlook

What keeps scrap prices suppressed?

- Surged graphite electrode prices
- Abundant ferrous scrap supply
- Competition in scrap and iron metallica market

MetalBulletin
Research

Increase in graphite electrode prices has been leaving little room for scrap prices to rise

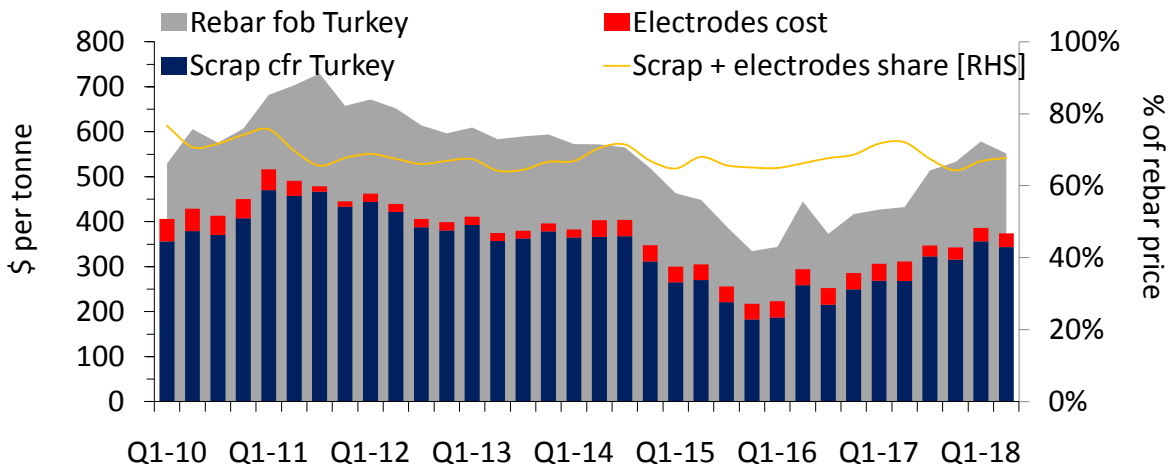

Source: Metal Bulletin, Metal Bulletin Research, MBR Cost Service

**Metal Bulletin
Research**

In fact, when graphite electrode prices in spot market spiked to \$30,000 per tonne, potential rise in scrap prices was restricted

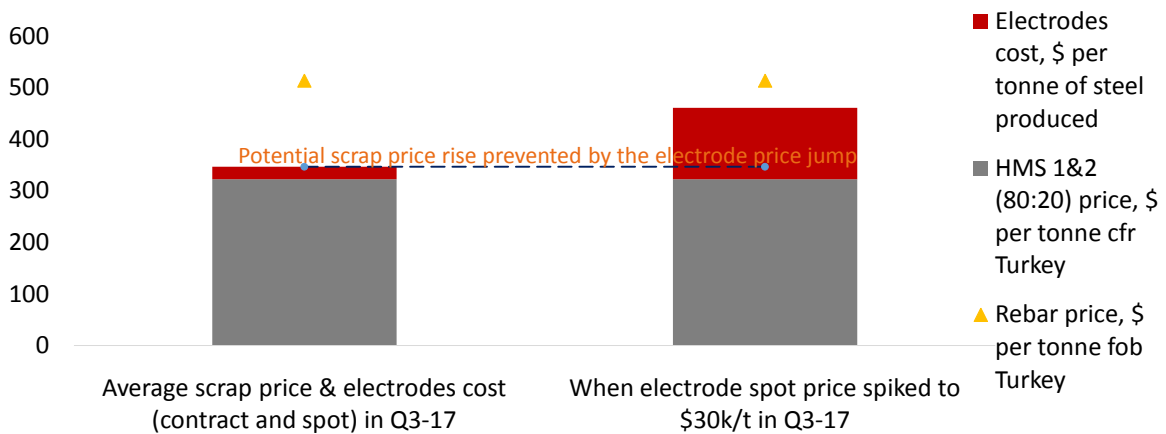

Source: Metal Bulletin Research, MBR Cost Service

**Metal Bulletin
Research**

Scrap sales as an indicator of supply volumes accelerated last year in key markets

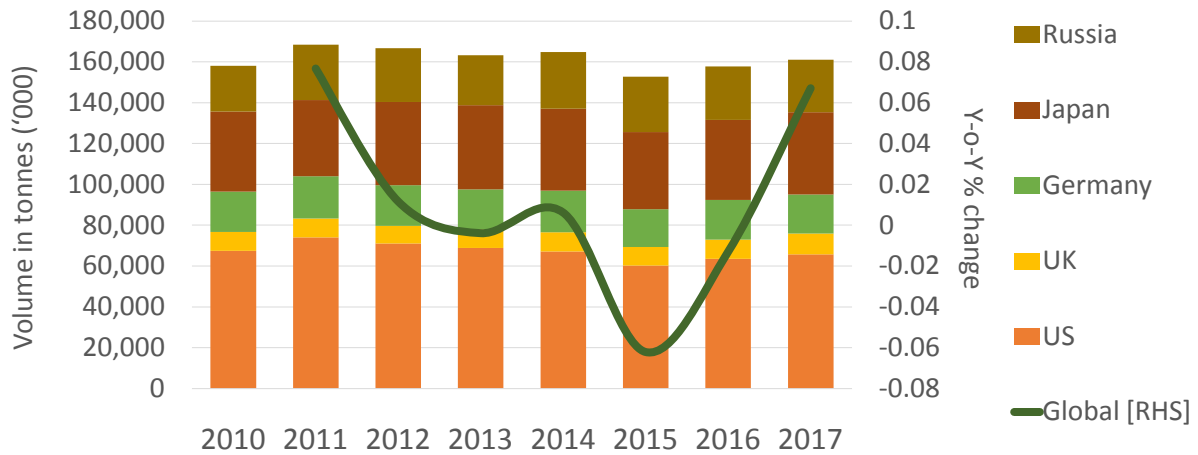

Source: Metal Bulletin Research

Metal Bulletin
Research

DRI/HBI is rapidly winning market share globally, major HBI exporters increased their combined exports last year and the trend is likely to continue

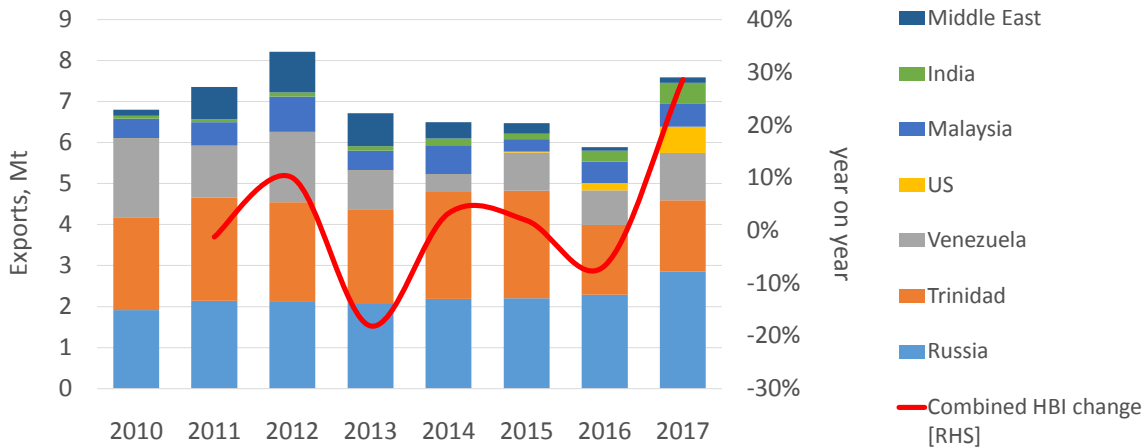

Source: ISSB, Metal Bulletin Research

Metal Bulletin
Research

Major importers are seeing ramping up HBI purchases at a higher pace than MPI

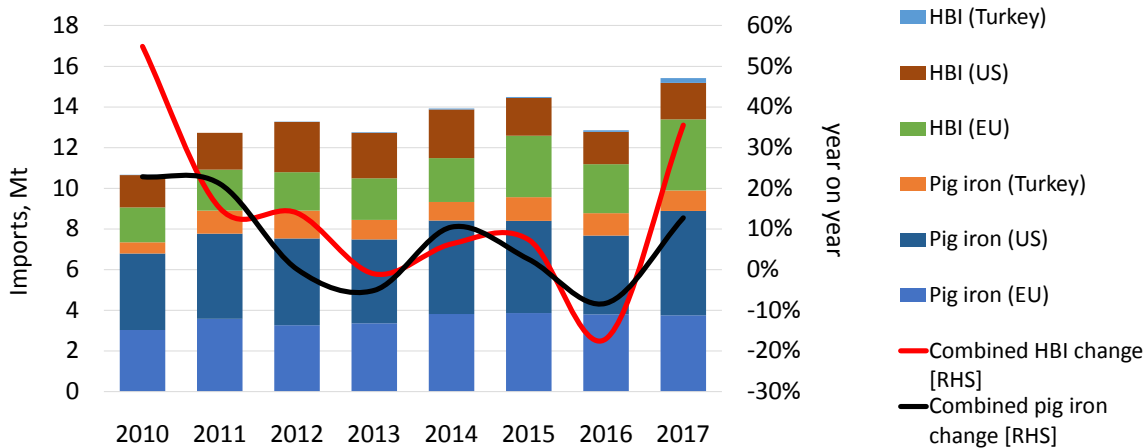

Source: ISSB, Metal Bulletin Research

Metal Bulletin
Research

So pig iron premiums over scrap have slid

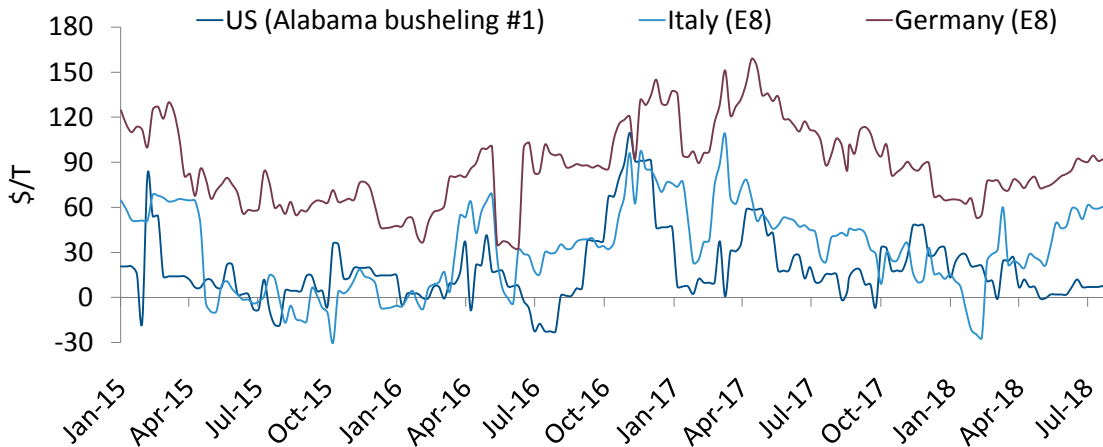

Source: Metal Bulletin, AMM, Metal Bulletin Research

Metal Bulletin
Research

Global Scrap & DRI Outlook

What is the relevance to Indian steel market?

- Raw material demand set to grow for both scrap and metallics
 - Greater reliance on scrap imports is anticipated

Metal Bulletin
Research

Rising steel output in India needs adequate supply of raw material which remains a challenge to source domestically...

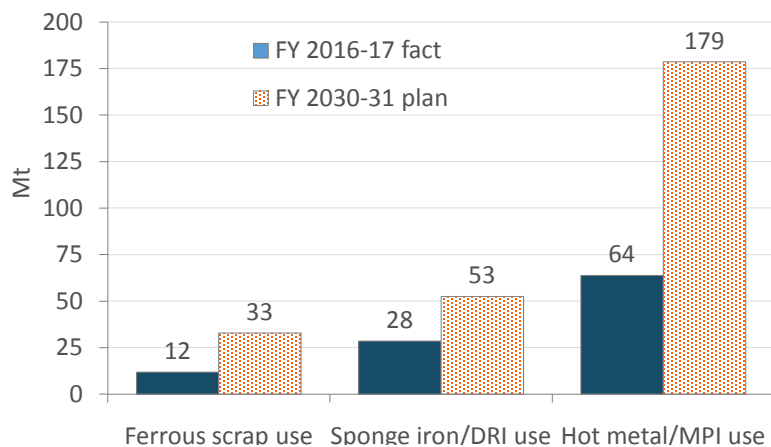

Source: Ministry of Steel (India), Metal Bulletin Research

- Scrap demand in India is projected to rise to almost 33Mt by 2030-31
- Requirements for DRI, known as sponge iron in India, will exceed 52.5Mt by FY2030-31
- Domestic industry still heavily relies on imports for coking coal which increased by 13% y/y in 2017/2018

Metal Bulletin
Research

Local shredding capacity will not prevent a rise in India scrap import volumes

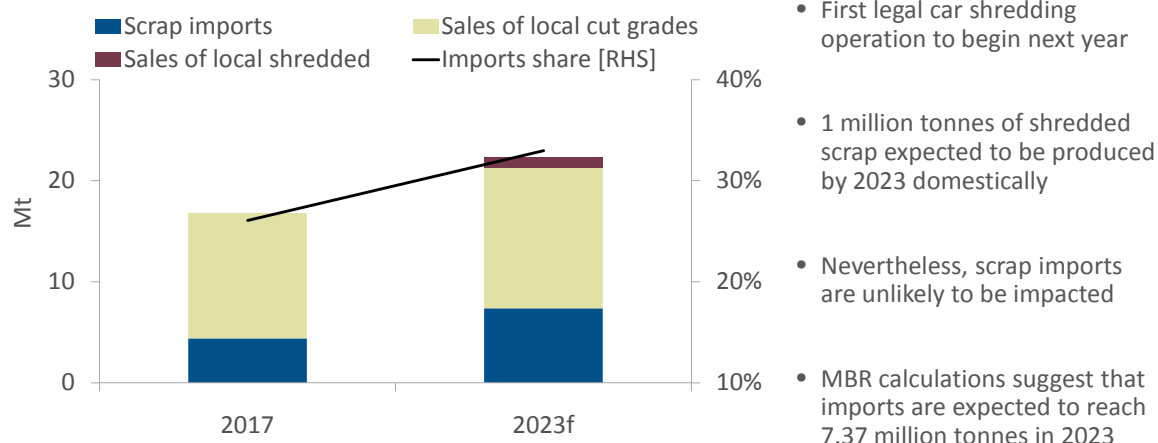

Source: ISSB, CERO, Metal Bulletin Research

- First legal car shredding operation to begin next year
- 1 million tonnes of shredded scrap expected to be produced by 2023 domestically
- Nevertheless, scrap imports are unlikely to be impacted
- MBR calculations suggest that imports are expected to reach 7.37 million tonnes in 2023

MetalBulletin
Research

Global Scrap & DRI Outlook

Growth projections for the Indian steel market

- Prevailing market scenario
- Comparison to growth in China and Globally
 - Downstream demand

MetalBulletin
Research

Indian Steel Industry: On An Upswing

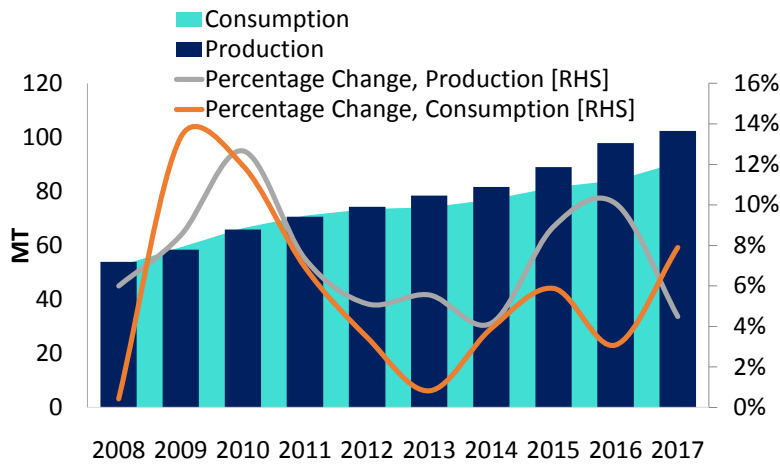

- Rise in domestic finished steel consumption against crude production figures
- Pace of growth have slightly slowed in 2017
- Increased domestic supply to seek improved consumption rates else exports will surge
- Weaker global steel demand to be a concern

Source: JPC, Ministry of Steel, Metal Bulletin Research *Note: Data based on Indian FY i.e. April 17-March 18

MetalBulletin
Research

Growth patterns in global crude steel production to be dominated by China. While China aims to control its steel glut, India sets in its ways...

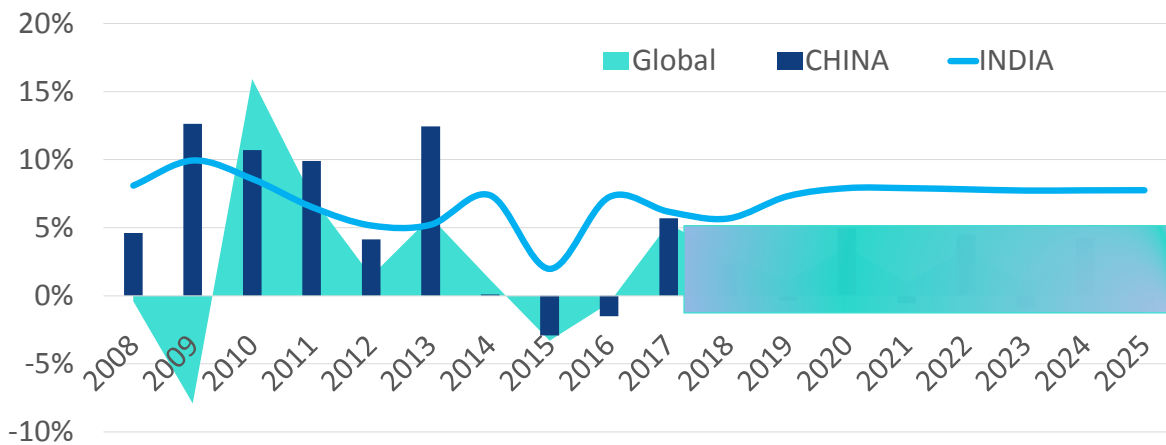

Source: WSA, Metal Bulletin Research

MetalBulletin
Research

Although demand from downstream markets remains supportive, pace of growth is relatively slow when compared to steel output

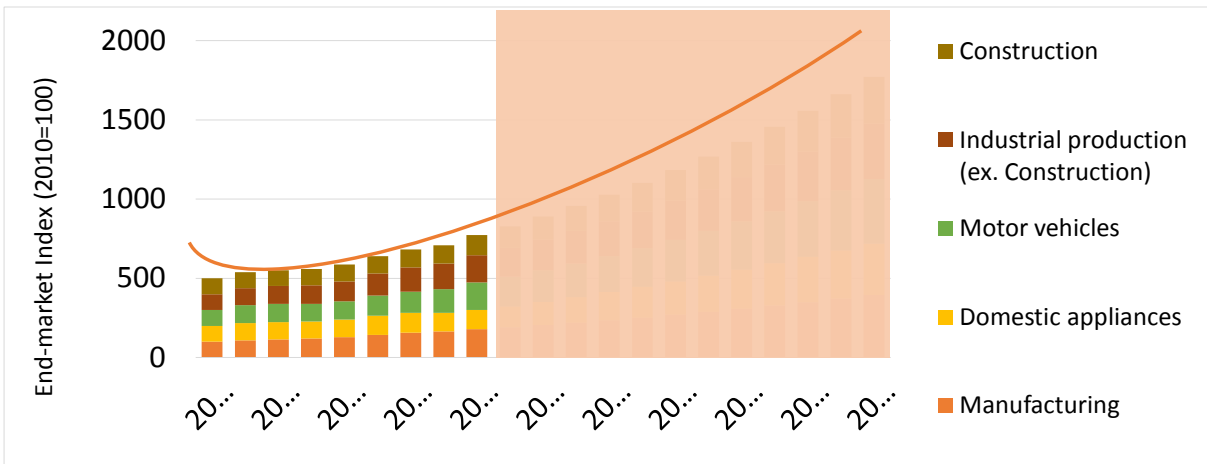

Source: Metal Bulletin Research

**Metal Bulletin
Research**

Population is expected to grow by circa 1% annually however per capita consumption needs to more than double to hit the 158kgs mark by 2030

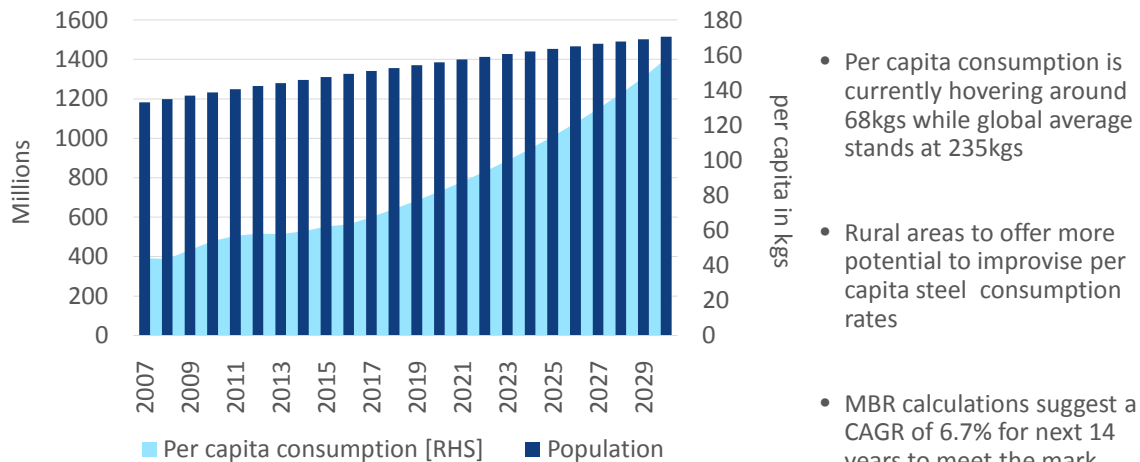

- Per capita consumption is currently hovering around 68kgs while global average stands at 235kgs
- Rural areas to offer more potential to improve per capita steel consumption rates
- MBR calculations suggest a CAGR of 6.7% for next 14 years to meet the mark

Source: Metal Bulletin Research

**Metal Bulletin
Research**

Key Takeaways

- In India, demand for both metallics and scrap will benefit from the rising steel output provided capacity expansion plans come to life
- Import scrap volumes are also set to increase, at least over the next five years, despite the launch of local shredding capacities by 2023
- While Indian steel industry offers ample potential for growth, limited accessibility to raw materials and lack of investor-friendly downstream projects harbour significant downside risks
- Globally, DRI/HBI is winning market share, adding to abundant supply of scrap and metallics, and the trend will persist with new capacity coming on stream
- Ferrous scrap prices theoretically have potential to increase, eating into the elevated margins at steel mills, but restraining factors will stay in place

MetalBulletin
Research

Meet The Team



ALONA YUNDA

Alona Yunda, senior metals analyst, leading global ferrous scrap & iron metallics market analysis and short-term forecasts at Metal Bulletin Research. Prior to joining the team in September 2017, for four years covered metallics and a wide range of semi- and finished steel products on the editorial side as a reporter in the CIS, Turkey and Mena team and then as an editor in the European steel team of Metal Bulletin in London. Before that, worked at Metal Expert in Ukraine for two years, overlooking East Asian steel markets, as well as providing analysis on iron ore prices in China. Obtained a master's degree in economics at the National Mining University in Dnepr, Ukraine.

EMAIL: alona.yunda@metalbulletin.com | TELEPHONE: +44 (0) 2075566022

LEE ALLEN

Lee Allen is a Metals Analyst at Metal Bulletin Research (MBR), responsible for covering ferrous scrap and long steel markets. Lee regularly contributes research to MBR's weekly raw materials and steel market trackers, providing analysis of recent market trends and price forecasts. Prior to becoming an analyst, Lee spent two years as a reporter for Metal Bulletin, assessing prices for Indian import ferrous scrap and UK domestic ferrous scrap among other products. He holds a bachelor's degree in French and Politics from the University of Bath, and speaks both French and German fluently.



EMAIL: lee.allen@metalbulletin.com | TELEPHONE: +44 (0) 2078276475



SHRUTI SALWAN

Shruti Salwan is a Metals Analyst with Metal Bulletin's steel & steel raw material research wing providing essential market and analytical insight on ferro-alloys and steel long products. She has expertise in providing industrial and economic analysis, price forecasts, and fundamentals around supply-demand dynamics across different commodities. Besides being a principal contributor in researching and generating reports for several bespoke consultancy projects, Shruti has also represented Metal Bulletin at several influential industry events around the world. She holds master's degree in business administration from Institute of Management Technology, India.

EMAIL: ssalwan@metalbulletinresearch.com | TELEPHONE: +44 (0) 2078276424

MetalBulletin
Research

Why Metal Bulletin Research?

Long and short-term forecast services for the global metals & mining industry

Steel

Steel Raw
Materials

Non-ferrous

Ores & Alloys

Tube & Pipe

Access independent, accurate forecasts based on 1,500+ trusted prices from Metal Bulletin and American Metal Market

Understand your industry with specialist analysis of market developments and underlying fundamentals

Plan ahead with confidence using valuable and reliable strategic insight

MetalBulletin
Research

Steel Scrap & Metallics Market Tracker

Comprehensive, independent analysis and forecasts for the ferrous scrap markets



- ✓ Forecasts for over 54 steel scrap and metallic prices
- ✓ Regular, independent analysis including supply/demand, international trade and freight data
- ✓ Direct access to the experienced, specialist team

Request a sample of the service: info@metalbulletinresearch.com

MetalBulletin
Research

Steel Raw Materials Market Tracker

Complete, independent price forecasting and analysis for steel raw materials



- ✓ 12 month forecasts for 57 different steel raw material prices
- ✓ Supply/demand & other market analysis
- ✓ Direct access to a specialist team
- ✓ Accurate price forecasts (over 99% for coking coal and over 98% for iron ore in Q2 2018)

Request a sample of the service: info@metalbulletinresearch.com

MetalBulletin
Research

Highlights of the 4th India International DRI Summit, 2018

Sponge Iron Manufacturers Association (SIMA) is a 26 years old all India apex industry body created to promote DRI and DRI based steel plants. They organized 4th India International DRI Summit 2018 on 13th August, 2018 at New Delhi . This event of national importance was attended by Union Steel Minister, Member, NITI Aayog, Secretary, Ministry of Steel, Chairman, SAIL, Chairman, JSPL, Jt. MD & CFO, JSW, experts from USA, UK ,Austria, China, UAE, captains of Indian steel industry, raw material and technology suppliers etc.

Glimpses of the event

Inaugural Session



(From left to right) Mr. Deependra Kashiva, Executive Director, SIMA, Mr. D.P. Deshpande, Chairman, SIMA, Dr. Aruna Sharma, Former Secretary (Steel), Chaudhary Birender Singh, Union Minister of Steel, Dr. V.K. Saraswat, Member, NITI Aayog, Mr. Naveen Jindal, Chairman, JSPL, Mr. Prakash Tatia, Director, Welspun Steel Ltd.



In his theme address Mr. Deependra Kashiva, Executive Director ,SIMA gave a over view of the summit and current steel and DRI scenario . He also flagged the issue of non availability of major raw materials at a affordable price.



Chaudhary Birender Singh, Union Steel Minister in his address as a Chief Guest stated that domestic steel consumption is growing rapidly and likely to grow 10/12% more in next 2-3 years.



Dr. Aruna Sharma, Former Secretary (Steel) in her address as a Guest of Honour highlighted the raw material issues and stated that the issues have been flagged to the concerned ministries and new mining policy is under process which will be presented to union cabinet shortly.



Dr. V.K. Saraswat, Member, NITI Aayog in his address as a Guest of Honour stated that Indian steel consumption has shown an impressive growth from 60kg per capita to 68kg per capita but we have a long way to go to achieve the world average per capita consumption. Indian DRI has a great future prospects and we need a steel policy where every milestone of steel production to be monitored and be competitive.



Mr. Naveen Jindal, Chairman, Jindal Steel & Power Ltd. also raised the issue of consistent availability of iron ore and coal at affordable prices .



Dignitaries releasing the KPMG report on "Assessment of Future Potential of Sponge Iron Industry in India".

Session – I - CEO Panel Discussion - Capacity Creation of Steel and Challenges



(L to R) Mr. Seshagiri Rao, Jt.MD & Group CFO,JSW Steel, Chaudhary Birender Singh,Minister of Steel, Mr.Nigel D'souza,Chief Analyst(metal) CNBC, (Moderator) Mr. Saraswati Prasad,Special Secretary & FA,MoS and Chairman,SAIL and Mr. A.K. Saxena,Executive Director,Bhushan Steel

Session-II -Technical Advances in DRI & DRI based Steel Production



(L to R) Mr.Todd M.Astoria,GM,Research & Technology Dev.,Midrex,USA, Mr.Partha Sengupta,President Corp.Services, JSW Steel (Moderator), Mr. Christian Boehm,Primetals Technologies,Austria and Mr. Anuj Agarwal, GM (Mktg) GAIL

Session-III – Metallics Scenario



(L to R) Mr. MV Subba Rao,CMD, KIOCL Ltd, on podium, Ms.Shruti Salwan,Metal Analyst,Metal Bulletin,UK, Mr. Prakash Tatia,Director,Welspun Steel (Moderator), Mr. Chris Barrington,Secretary General,IIMA, UK

Session-IV - Innovation in Coal Based DRI Production



(L to R) Mr. TANG En,Wuhan COSRED,China, Mr. DP Deshpande,Chairman,SIMA (Moderator), Mr.Vivek Garg,Head DRI Business,JSPL, Dr.RR Sonde, Executive Vice President,Thermax Ltd.

Sesion-V - Challenges and Prospects of DRI and DRI Based Steel Production



(L to R) Mr. Juan Cairo,DRI Tech.Support Manager, Manoir Pitres,France, Mr. J.Satyanarana,Director,Ferrexpo Middle East Fze,UAE, Mr. Deependra Kashiva,Executive Director, SIMA (Moderator) Ms. Aditi Trafdar,Technical Director,M.N.Dastur & Co., Mr. Pranay Shukla,Senior Ayalyst, Mercuria Trading (I)Pvt.Ltd.

Congratulations our esteemed members for receiving **Secondary Steel Sector Award 2016-17**



M/S SMC Power Generation Ltd. was given **Golden Award** and a Certificate by Union Minister of Steel under the category Direct Reduction Iron – Electric Arc Furnace/induction Furnace-RM . Award was received by **Mr. M. C. Aggarwal, Mr. C.P. Aggarwal & Mr. Akshay Aggarwal**



M/S Shri Bajrang Power & Ispat Ltd. was given **Golden Award** and a Certificate by Union Minister of Steel under the category Direct Reduction Iron – Electric Arc Furnace/induction Furnace-RM . Award was received by **Mr. Narendra Goel and Mr. S.K. Goyal.**

Congratulations our esteemed members for receiving **Secondary Steel Sector Award 2016-17**



M/S Sunflag Iron & Steel Co. Ltd. was given **Golden Award** and a Certificate by Union Minister of Steel under the category Mini blast furnace (with or without DRI) – EAF/EOF with/without RM. Award was received by **Mr. Jagannathan Somu.**



M/S Pulkit Metals Ltd was given **Silver Award** and Certificate under the category EAF/IF-RM from , Union Minister of Steel . Award was received by **Mr. Puushpit Garg**

Congratulations our esteemed member – **M/s Suraj Products Ltd.** for receiving **Pollution Control Appreciation Award 2018** from **State Pollution Control Board, Odisha**



Congratulations



Congratulations

JSW Steel Limited

and



Minera Steel & power Pvt. Ltd.

For Getting Captive Iron Ore Mines

In the State of Karnataka

Congratulations